

## P 320



### Installation and Service Manual

# Declaration of conformity

The appliance complies with the standard model described in declaration of compliance . It is manufactured and distributed pursuant to the requirements of european directives. The original declaration of conformity is available from the manufacturer.

**DÉCLARATION DE CONFORMITÉ CE**  
**EG - VERKLARING VAN OVEREENSTEMMING**  
**EC - DECLARATION OF CONFORMITY**  
**EG - KONFORMITÄTSERKLÄRUNG**

Fabricant/Manufacturer/Hersteller/Fabrikant : REMEHA B.V  
Adresse/Adres/Adress : Kanalzuid 110  
Ville, pays Stad, Land/City, Country/Land, Ort : NL 7332 BD APELDOORN  
Tel : +31 55 549 69 69  
Fax : +31 55 549 64 96

déclare ici que les produit(s) suivant(s) : P 320  
verklaart hiermede dat de toestel(len) : 4, 5, 6, 7, 8, 9 éléments  
this is to declare that the following product(s)  
erklärt hiermit das die Produk(te)

Mise en circulation par : voir fin de notice

répond/répondent aux directives CEE suivantes:  
voldoet/voldoen aan de bepalingen van de onderstaande EEG-richtlijnen:  
is/are in conformity with the following EEC-directives:  
den Bestimmungen der nachfolgenden EG-Richtlinien entspricht/entsprechen:

CEE-Directive: 92/42/CEE normes appliquées, toegepaste normen:  
EEG-Richtlijn: 92/42/EEG tested and examined to the following norms:  
EEC-Directive: 92/42/EEC verwendete Normen:  
EG-Richtlinie: 92/42/EWG EN 303.2(1999), EN 304(1993)

90/396/CEE EN 303.3 (1999)  
90/396/EEG  
90/396/EEC  
90/396/EWG

73/23/CEE DIN EN 50165(2001) EN 50165 (1997+A1:2001)  
73/23/EEG DIN EN 60335-1(2003), EN 60335-1(2002)  
73/23/EEC  
73/23/EWG

89/336/CEE EN 55014-1(2000+A1:2001)  
89/336/EEG EN 55014-2(1997+A1:2001)  
89/336/EEC EN 61000-3-2(2000),  
89/336/EWG EN 61000-3-3(1995+A1:2001)  
EN55022 classe B (1998+A1 :2000)

97/23/CEE (art.3 section 3)  
97/23/EEG (art. 3, lid 3)  
97/23/EEC (article 3, sub 3)  
97/23/EWG (Art. 3, Absatz 3)

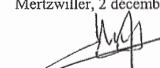

Mertzwiller, 2 décembre 2008

  
Jean-Claude GIRARDIN  
Directeur des opérations industrielles  
Recherche et développement

C001879-B

# Contents

<b>1</b>	<b>Safety instructions</b>	<b>4</b>
1.1	General safety instructions	4
1.1.1	Fire hazard	4
1.1.2	Risk of intoxication	4
1.1.3	Risk of being burnt	4
1.1.4	Risk of damage	4
1.2	Recommendations	5
1.3	Liabilities	5
1.3.1	Manufacturer's liability	5
1.3.2	Installer's liability	5
<b>2</b>	<b>About this manual</b>	<b>6</b>
2.1	Symbols used in the manual	6
2.2	Abbreviations	6
2.3	Homologations	6
2.3.1	Certifications	6
2.3.2	Directive 97/23/EC	6
<b>3</b>	<b>Technical description</b>	<b>7</b>
3.1	General description	7
3.2	Composition of the range	7
3.3	Main dimensions	8
<b>4</b>	<b>Installation</b>	<b>9</b>
4.1	Boiler location	9
4.2	Ventilation	10
4.3	Mounting	10
4.4	Hydraulic connections	10
4.4.1	Important recommendations on connecting the heating circuit to the boiler and the drinking water system	10
4.4.2	Important recommendations for connecting the boiler to the heating circuit	12
4.4.3	Filling the system	12
4.4.4	Sludge removal	13
4.5	Chimney connection	13
4.5.1	Flue size	13
4.5.2	Chimney connection	13
4.6	Fuel-oil or gas connections	13
4.7	Electrical connections	14
<b>5</b>	<b>Maintenance</b>	<b>15</b>
5.1	Sweeping	15
5.2	Cleaning the casing material	16
5.3	Precautions required in the case of long boiler stops	16
5.4	Precautions required if the heating is stopped when there is a risk of freezing	16
<b>6</b>	<b>Burner maintenance</b>	<b>17</b>
<b>7</b>	<b>System maintenance</b>	<b>17</b>
7.1	Water level	17
7.2	Draining	17
<b>8</b>	<b>Type plate</b>	<b>18</b>
<b>9</b>	<b>Spare parts</b>	<b>19</b>

# 1 Safety instructions

## Danger

This appliance can be used by children aged from 8 years and above and persons with reduced physical, sensory or mental capabilities or lack of experience and knowledge if they have been given supervision or instruction concerning use of the appliance in a safe way and understand the hazards involved. Children shall not play with the appliance. Cleaning and user maintenance shall not be made by children without supervision.

 Any operation on the installation must be performed by a qualified technician respecting professional regulations and in accordance with this document.

 Before any work, switch off the mains supply to the appliance. Protect the installation against any unwanted restarts.

 For a proper operating of the boiler, follow carefully the instructions.

 The manufacturer is not liable for any improper use of the appliance or failure to maintain or install the unit correctly (the user shall take care to ensure that the system is installed by a qualified engineer).

 Work on electrical equipment must be carried out by a qualified professional in compliance with the prevailing regulations.

 Check that the appliance is properly set for the type of gas used.

 Keep to the polarity shown on the terminals: phase (L), neutral (N) and earth  $\perp$ .

 Check the seal on the gas and water pipe connections.

 We shall not accept any responsibility for any damage and disturbance arising from not following these instructions.

 Incorrect use or unauthorised modifications to the installation or the equipment itself invalidate any right to claim.

## 1.1 General safety instructions

### 1.1.1 Fire hazard

 Do not stock products of an inflammable nature close to the appliance.

### 1.1.2 Risk of intoxication

 Do not obstruct the air inlets in the room (even partially).

 If you smell flue gases

1. Switch the appliance off
2. Open the windows
3. Evacuate the premises
4. Contact a qualified professional

### 1.1.3 Risk of being burnt

 Depending on the settings of the appliance:

- The temperature of the flue gas conduits may exceed 60°C

- The temperature of the radiators may reach 95°C
- The temperature of the domestic hot water may reach 65°C

### 1.1.4 Risk of damage









 Do not stock chloride or fluoride compounds close to the appliance.

 Install the appliance in frost-free premises.

Do not neglect to service the appliance: Contact a qualified professional or take out a maintenance contract for the annual servicing of the appliance.

## 1.2 Recommendations

---

-  For a proper operating of the boiler, follow carefully the instructions.
-  Any intervention on the appliance and heating equipment must be carried out by a qualified engineer.
-  The manufacturer is not liable for any improper use of the appliance or failure to maintain or install the unit correctly (the user shall take care to ensure that the system is installed by a qualified engineer).
-  Work on electrical equipment must be carried out by a qualified professional in compliance with the prevailing regulations.
-  Check that the appliance is properly set for the type of gas used.
-  Keep to the polarity shown on the terminals: phase (L), neutral (N) and earth  $\frac{\perp}{\perp}$ .
-  Check the seal on the gas and water pipe connections.
-  We shall not accept any responsibility for any damage and disturbance arising from not following these instructions.

## 1.3 Liabilities

---

### 1.3.1 Manufacturer's liability

---

Our products are manufactured in compliance with the requirements of the various applicable European Directives. They are therefore delivered with **CE** marking and all relevant documentation. In the interest of customers, we are continuously endeavouring to make improvements in product quality. All the specifications stated in this document are therefore subject to change without notice.

Our liability as the manufacturer may not be invoked in the following cases:

- Failure to abide by the instructions on installing the appliance
- Failure to abide by the instructions on using the appliance
- Faulty or insufficient maintenance of the appliance

### 1.3.2 Installer's liability

---

The installer is responsible for the installation and commissioning of the appliance. The installer is required to observe the following instructions:

- Read and follow the instructions given in the manuals provided with the appliance
- Install the appliance in accordance with the legislation and standards currently in force
- Perform the initial start up and carry out any checks necessary
- Explain the installation to the user
- If a maintenance is necessary, warn the user of the obligation to check the appliance and maintain it in good working order
- Give all the instruction manuals to the user

# 2 About this manual

---

## 2.1 Symbols used in the manual

---

 **Caution danger**  
Risk of injury and damage to equipment. Attention must be paid to the warnings on safety of persons and equipment.

 **Specific information**  
Information must be kept in mind to maintain comfort.

 **Reference**  
Refer to another manual or other pages in this instruction manual.

## 2.2 Abbreviations

---

▶ **DHW:** Domestic hot water.

▶ **PPS:** Polypropylene hardly inflammable.

▶ **3CE:** Collective conduit for sealed boiler

**Hi:** Lower heating value LHV (Nett)

**Hs:** Higher heating value HHV (Gross)

## 2.3 Homologations

---

### 2.3.1 Certifications

---

#### ■ In general

**CE identification no: 1312 BR 46 17 (Base):**  
France, Germany, Austria, Belgium, Spain, Italy, Luxemburg, Poland, Portugal, Czech Republic, Slovenia, Switzerland.

**CE identification no: 1312 BR 47 83 (Export):**  
Algeria, Bulgaria, China, Finland, Greece, Ireland, Jordan, Lebanon, Morocco, Norway, Romania, Russia, Syria, Tunisia, Turkey.

#### ■ In particular for Switzerland:

**Accreditation no. OFEFP: 293010**

**Accreditation no. AEAI: 8088**

### 2.3.2 Directive 97/23/EC

---

Gas and oil boilers with a maximum operating temperature of 110°C and hot water tanks with a maximum operating pressure of 10 bar pertain to article 3.3 of the directive, and therefore, cannot be CE-marked to certify compliance with the directive 97/23 EC.

The boilers and hot water tanks are designed and manufactured in accordance with the sound engineering practice, as requested in article 3.3 of the directive 97/23/EC, it is certified by compliance with the directives 90/396/EC, 92/42/EC, 2006/95/EC and 2004/108/EC.

# 3 Technical description

## 3.1 General description

The boilers of the P 320 range are pressurised hot water boilers designed for connecting to a flue pipe which require a separate automatic fuel-oil or gas burner.

The useful power of P 320 boilers is between 55 and 280 kW.

### Models available

Boiler with control panel, which may be fitted with an optional Rematic 2945 C3K control unit for heating only or heating and domestic hot water production.

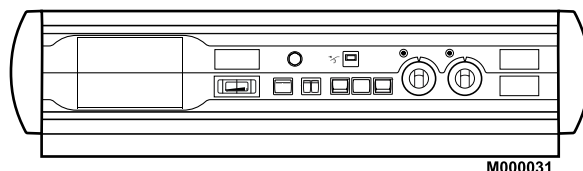

## 3.2 Composition of the range

Maximum operating pressure: 6 bar

Safety thermostat setting: 110 °C

Boiler thermostat setting: 30 to 90°C

Boiler		P 320-4	P 320-5	P 320-6	P 320-7	P 320-8	P 320-9
Useful output	<b>kW</b>	55-90	90-115	115-150	150-185	185-230	230-280
Power input	<b>kW</b>	61-100	100-128	128-167	167-206	206-256	256-311
Number of sections		4	5	6	7	8	9
Water content	<b>l</b>	96	116	136	156	176	196
Water resistance	$\Delta T = 10K$ (1)	<b>mbar</b>	11	18	31	46	105
	$\Delta T = 15K$ (1)	<b>mbar</b>	4.6	7.4	14.2	19.5	30.1
	$\Delta T = 20K$ (1)	<b>mbar</b>	2.6	4.2	8	11	17
Pressure in the furnace for nozzle pressure = 0	 <b>mbar</b>	0.2	0.4	0.7	1.2	1.8	2.2
Flue gas temperature <sup>(1)</sup> <sup>(3)</sup>	<b>°C</b>	< 200	< 190	< 190	< 190	< 190	< 190
Mass flue gas flow rate <sup>(1)</sup>	Fuel oil	<b>Kg/h</b>	149	191	248	306	381
	Gas	<b>Kg/h</b>	160	206	270	331	411
Combustion chamber	Inscribed diameter	<b>mm</b>	377	377	377	377	377
	Depth	<b>mm</b>	571	731	891	1051	1211
	Volume	<b>m<sup>3</sup></b>	0.096	0.122	0.148	0.174	0.200
Maintenance consumption*	$\Delta T = 30K$	<b>%</b>	0.150	0.135	0.125	0.115	0.100
Shipping weight	<b>kg</b>	599	724	833	968	1090	1217

\*Maintenance consumption: total heat emission when the burner is off as a percentage of the nominal input power when the difference between the mean boiler temperature and the room temperature is 30 K.

<sup>(1)</sup>Nominal operation (top boiler power)

<sup>(2)</sup>CO<sub>2</sub> = 13.1 to 13% with fuel oil and 9.5% with natural gas.

<sup>(3)</sup>Boiler temperature : 80 °C

Ambient temperature : 20 °C

**i** 1 mbar = 10 mmWG = 10 daPa

 **In order for the boiler to operate correctly, it is imperative to respect the draught at the nozzle: 0 at the nozzle.**

### 3.3 Main dimensions

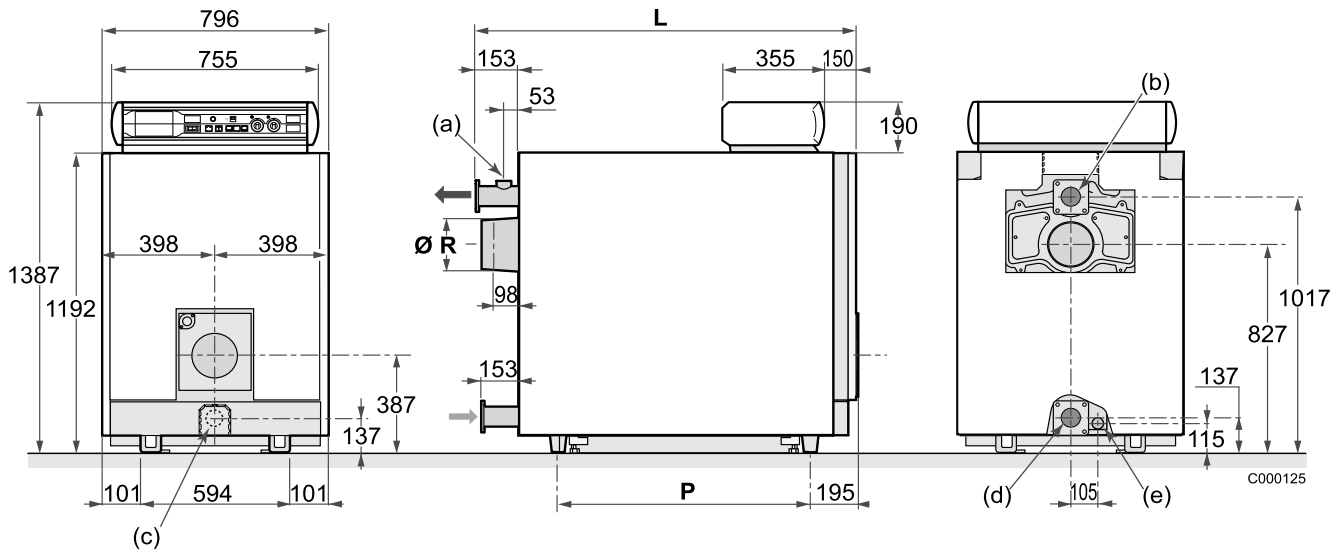

- (a) Rp 1 1/2 socket for the safety control unit
- (b) 2 1/2 heating outlet (flange + counter flange)
- (c) Sludge removal hole Ø Rp 2 1/2
- (d) 2 1/2 heating return (flange + counter flange)
- (e) Rp 1 1/2 draining outlet (supplied with plug)

	P 320-4	P 320-5	P 320-6	P 320-7	P 320-8	P 320-9
L (mm)	991	1151	1311	1471	1631	1791
P (mm)	490	650	810	970	1130	1290
R (mm)	180	180	180	200	200	200



# 4 Installation

## 4.1 Boiler location

The P320 boiler does not require a special base for its assembly. Their closed furnace system means that the floor need not have refractory properties. All you have to ensure is that the floor can support the weight of the boiler when it is fitted for operation. If the boiler location is not determined precisely, leave enough space around the boiler to facilitate monitoring and maintenance operations.

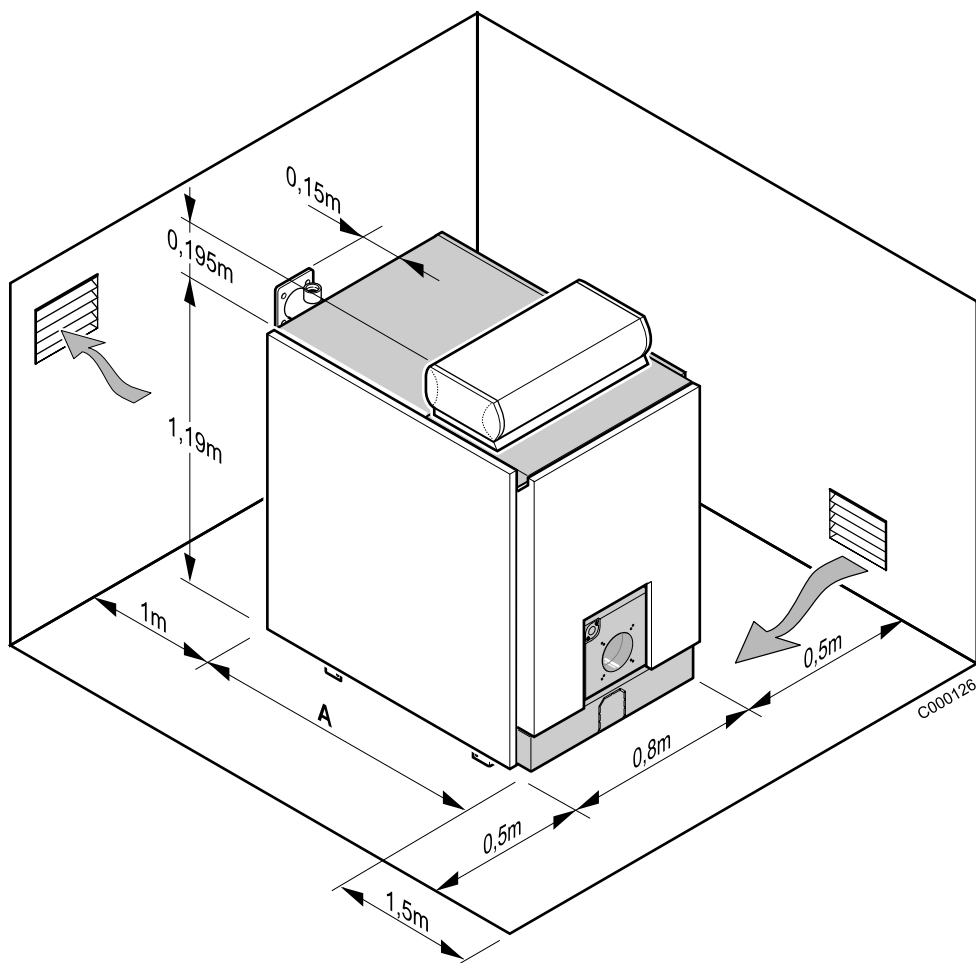

Boiler	P 320-4	P 320-5	P 320-6	P 320-7	P 320-8	P 320-9
A	838	998	1158	1318	1478	1638

**!** Pay attention to the overall volume of the burner when the door is open. To install several boilers in cascade, these dimensions should be adapted accordingly.

## 4.2 Ventilation

---

The location of air inlets in relation to the high ventilation openings shall ensure that the air is renewed in the entire volume of the boiler room.

It is in any case imperative to conform to the local regulations in force.

### **Caution:**

In order to avoid damage to the boiler, it is necessary to prevent the contamination of combustion air by chlorine and/or fluoride compounds, which are particularly corrosive.

These compounds are present, for example, in aerosol sprays, paints, solvents, cleaning products, washing products, detergents, glues, snow clearing salts, etc.

Therefore:

- Do not pull in air evacuated from premises using such products: hairdressing salons, dry cleaners, industrial premises (solvents), premises containing refrigeration systems (risk of refrigerant leakage), etc.
- Do not stock such products close to the boilers.

**If the boiler and/or peripheral equipment are corroded by such chloride or fluoride compounds, the contractual guarantee cannot be applied.**

## 4.3 Mounting

---

 For mounting instructions, see installation instructions.

## 4.4 Hydraulic connections

---

### 4.4.1 Important recommendations on connecting the heating circuit to the boiler and the drinking water system

---

Installation must be carried out in accordance with the prevailing regulations, the codes of practice and the recommendations in these instructions.

The expansion vessel must be connected directly to the boiler without valves or stop valves.

Likewise, the safety valve must be connected directly to the boiler without valves or stop valves.

#### **Example of an installation:**

The example of an installation shown below does not cover every possible configuration. Its sole aim is to draw your attention to the basic rules to be respected. Comply at all times with the codes of practice and the prevailing national or local regulations.

## P 320 boiler with domestic hot water production using an independent tank

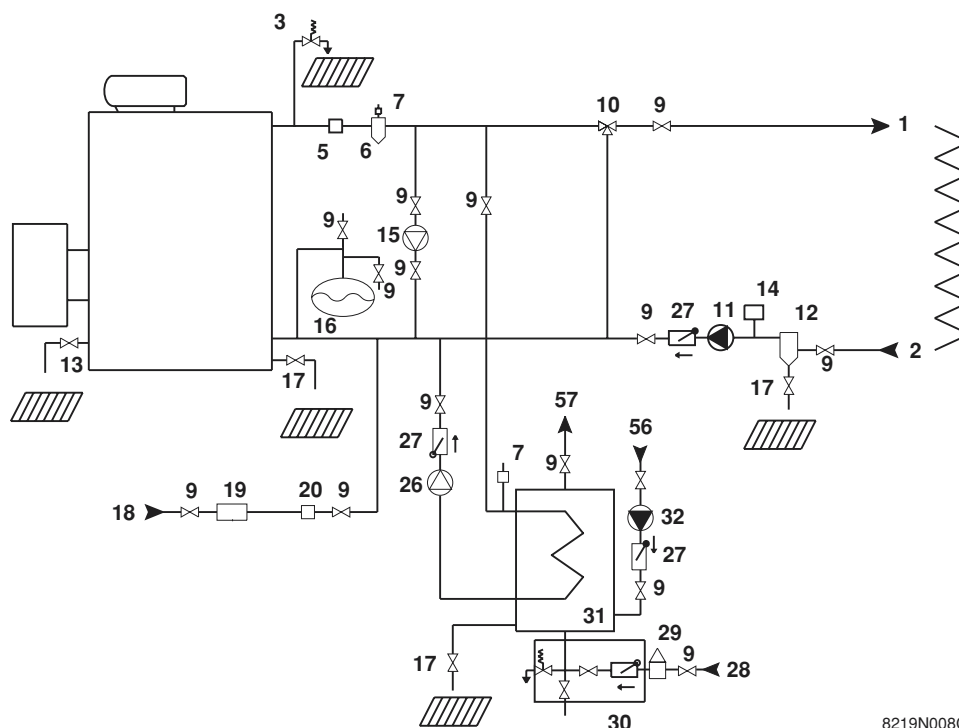

8219N008C

1. Heating flow
2. Heating return
3. 3 bar safety valve + manometer
5. Flow switch
6. Air separator
7. Automatic air vent
9. Isolating valve
10. 3-way mixing valve
11. Boiler pump
12. Sludge decanting pot (particularly recommended on older installations)
13. Flush valve
14. Water low safety pressure-sensitive switch
15. Shunt pump
16. Expansion vessel
17. Drain cock
18. Heating circuit filling (with disconnecter depending on prevailing regulations)
19. Water treatment if TH > 25°
20. Water meter
26. DHW load pump
27. Non-return valve
28. Domestic cold water inlet
29. Pressure reducer (if mains pressure > 5.5 bar)
30. Safety unit calibrated to 7 bar with indicator type discharge
31. Independent domestic hot water tanks
32. Domestic hot water loop pump (optional)
56. Domestic hot water circulation loop return
57. Domestic hot water outlet

## 4.4.2 Important recommendations for connecting the boiler to the heating circuit

Installation must be carried out in accordance with the prevailing regulations, the codes of practice and the recommendations in these instructions.

### ► Minimum safety valve flowrate as a function of maximum boiler nominal output:

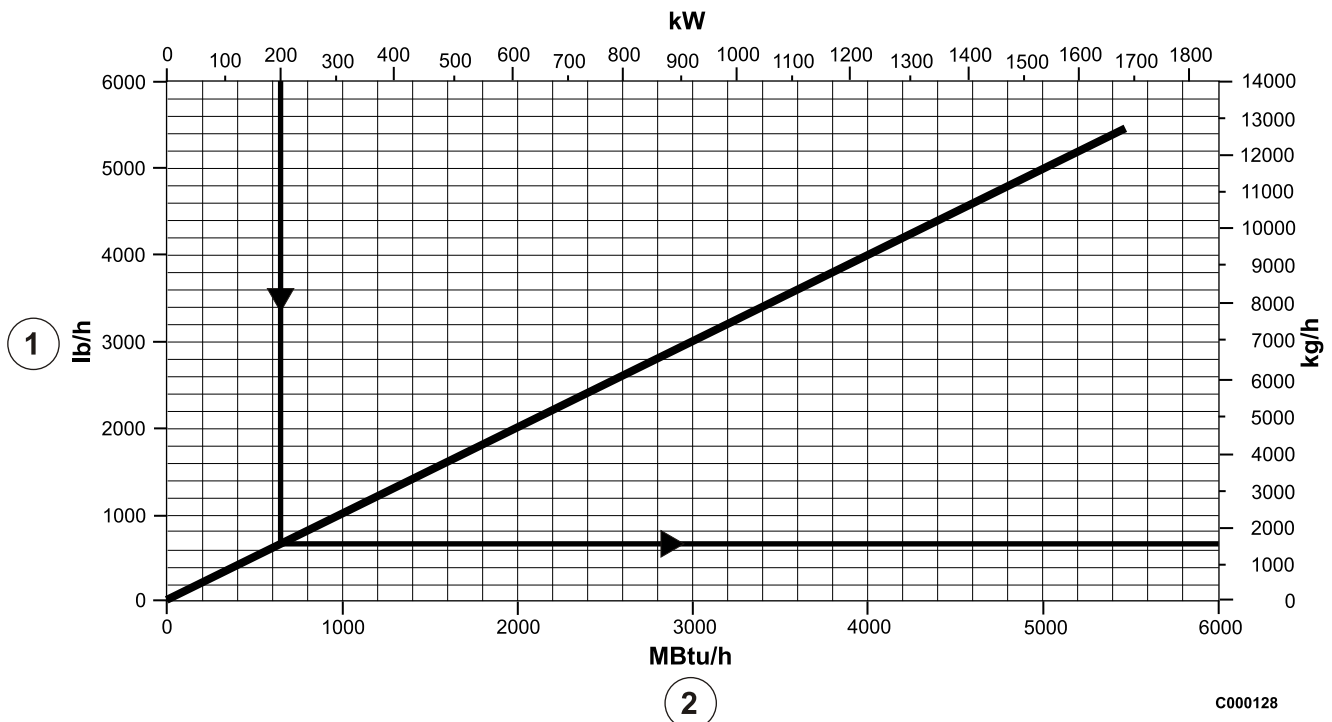

- ① Minimum relieving capacity
- ② Maximum gross boiler output

### Example

Maximum boiler nominal output is 200 kW.

Minimum safety valve flowrate must be 1500 Kg/h.

### ► Water flow in the boiler :

The water flow in the boiler when the burner is operating must correspond with the following formulae:

- Nominal water flow  $Q_n = 0.86 P_n / 20$
- Minimum flow  $Q_{min} = 0.86 P_n / 45$  (this flow also corresponds with the minimum recycle flow in the boiler)
- Maximum water flow  $Q_{max} = 0.86 P_n / 5$

$Q_n$  = flow in  $m^3/h$

$P_n$  = Nominal output (full boiler output) in kW.

### ► Operation in cascade

After stopping the burner:

- Timeout required before the order to close a 2 way valve: 3 min
- Switch a possible shunt pump (located between the boiler and a butterfly valve) off via the end of run contact of the butterfly valve

### ► Operation with 2-stage burner

- The water temperature in the boiler is maintained at 50°C or more; The first stage must be set to a minimum of 30% of the nominal stage
- Operation at modulated low temperature (minimum outlet temperature: 30°C); The first stage must be set to a minimum of 50% of the nominal stage

### ► Operation with modulating burner

- The water temperature in the boiler is maintained at 50°C or more: The burner can modulate down to 30% of the nominal stage
- Operation at modulated low temperature (minimum outlet temperature: 30°C); The burner can modulate down to 50% of the nominal stage

## 4.4.3 Filling the system

Filling shall be performed with a low flow rate from a low point in the boiler room in order to ensure that all the air in the boiler is bled from the high point of the system.

All the pumps must be stopped before filling (included shunt pump(s)).

 **VERY IMPORTANT: Instructions for starting up the boiler for the first time after the system is fully or partly drained:** If all the air is not bled naturally to an expansion vessel which opens out onto the air, the system must include manual bleeder valves, in addition to automatic bleeder valves with the capability to bleed the system by themselves when it is operating, the manual bleeder valves are used to bleed all the high points of the system and to make sure that the filled system is free of air before the burner is turned on.

 **Do not add cold water suddenly into the boiler when it is hot.**

#### 4.4.4 Sludge removal

---

A tapped Ø 1" 1/2 hole with a plug has been provided on the bottom of the front of the boiler.. Fit a 1/4 turn valve (not supplied) on the opening to remove the sludge.

Sludge removal leads to the draining of large quantities of water, so remember to refill the system after the operation.

**Note:**

never replace a boiler in an existing system without carefully rinsing the system first. Install a sludge decanting pot on the return pipe, very close to the boiler.

### 4.5 Chimney connection

---

The high-performance features of modern boilers and their use in specific conditions as a result of the advance in burner technology (e.g. first-stage or low modulation range operation) lead to very low flue gas temperatures (<160°C).

For this reason:

- Use flue gas pipes designed to enable the flow of condensates which may result from such operating modes in order to prevent damage to the chimney.
- Install a draining tee at the bottom of the chimney.

The use of a draught moderator is recommended as well.

#### 4.5.1 Flue size

---

Refer to applicable regulations while determining the size of the flue. Please note that P 320 boilers have pressurised and tight furnaces and that the pressure at the connection to the chimney must not exceed 0 mbar, unless special sealing precautions have been taken, for instance in order to connect a static condenser/regenerator.

#### 4.5.2 Chimney connection

---

The connection shall be removable, and offer minimum load losses, i.e. it must be as short as possible with no sudden change in section.

Its diameter shall always be at least equal to that of the boiler outlet, i.e.:

Ø 180 mm: for 4 to 6 sections

Ø 200 mm: for 7 to 9 sections

Fit a measuring point (Ø 10 mm hole) on the flue, in order to adjust the burner (combustion check).

### 4.6 Fuel-oil or gas connections

---

 Refer to the instructions supplied with the burner.

 The burner head deflector must be flush with the insulation of the burner door.

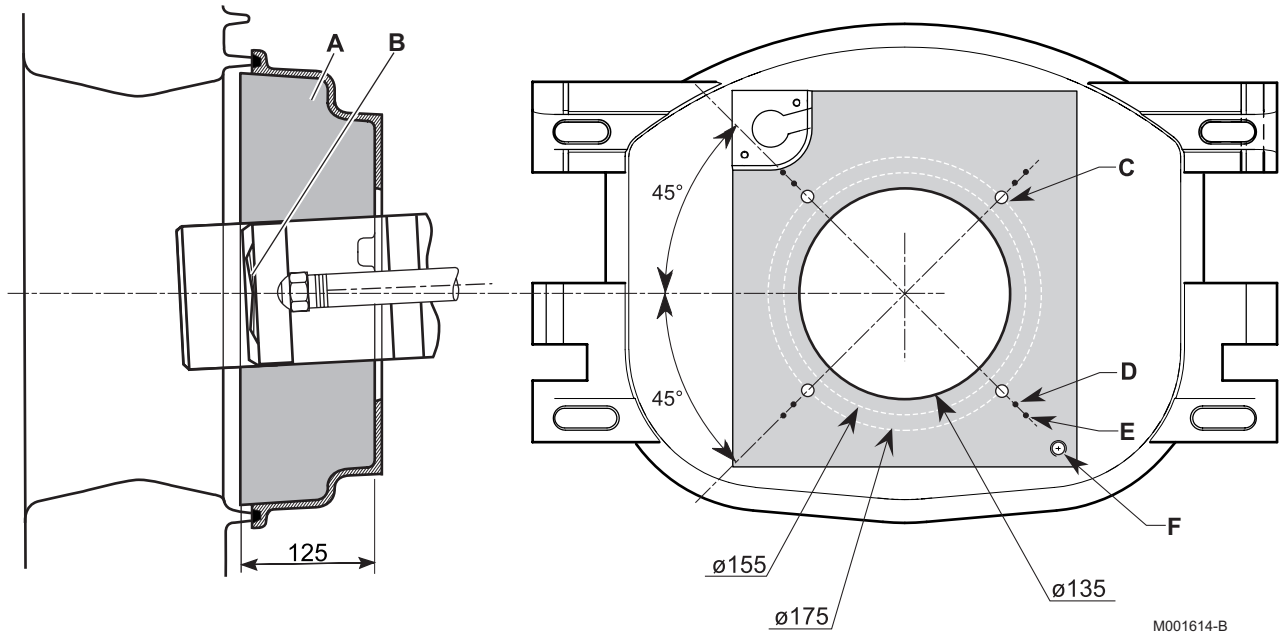

A: Furnace door insulation

B: Turbulator

C: 4 markings on Ø 170

D: 4 markings on Ø 200

E: 4 markings on Ø 220

## 4.7 Electrical connections

 Refer to the connection instructions supplied with the control panel..

# 5 Maintenance

 The operations described below shall only be performed with the boiler and power supply off.

## 5.1 Sweeping

The boiler will only operate efficiently if the exchange surfaces are kept clean.

The boiler should be cleaned as soon as required and as the chimney, **at least once a year or more**, depending upon applicable regulations and specific needs.

### ■ Cleaning the flue gas circuit

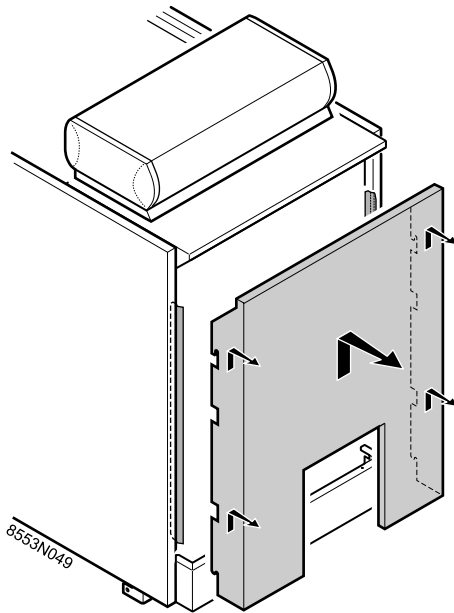

- Switch off the boiler electrical power supply.
- Unhook the front panel.
- Open the cleaning door (top door) by unscrewing the 4 closing nuts (17 mm spanner),
- Remove the baffle plates,
- Carefully sweep the flue ways with the brush supplied for that purpose,
- Also sweep the baffle plates and the front panel,
- If possible, use a vacuum cleaner,
- Replace the baffle plates,
- Close the door.

### ■ Cleaning the combustion chamber

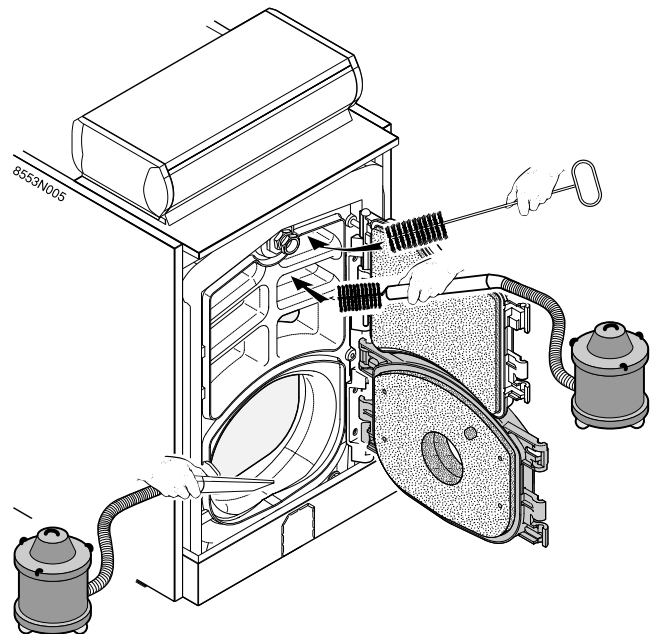

- Unscrew the 4 closing nuts and open the furnace door.
- Brush out the inside of the furnace.
- Use a vacuum cleaner to remove any soot which has accumulated in the combustion chamber.
- Close the door and replace the front panel.

## ■ Positioning of the baffles

**⚠** The first two baffles on the two lower flue ways are fitted with stops to position them in the right place.

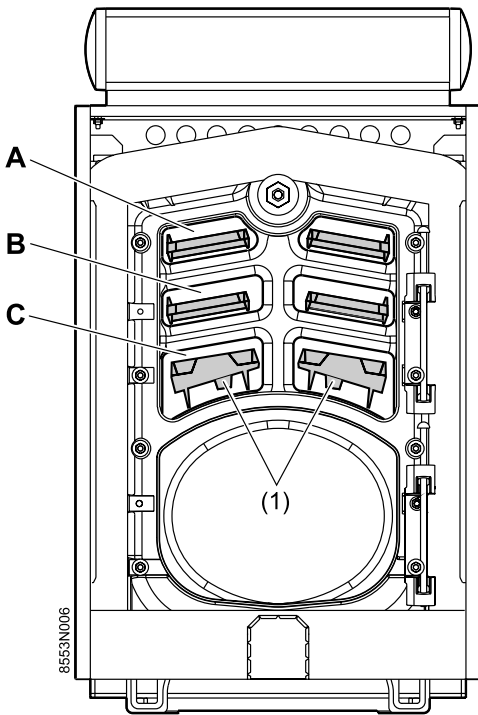

(1) Stop

## ■ Cleaning the flue gas box

- Remove the left and right cleaning hatches from the flue gas box (2 butterfly screws) and use a vacuum cleaner to remove any soot which has accumulated
- Replace the cleaning hatches.

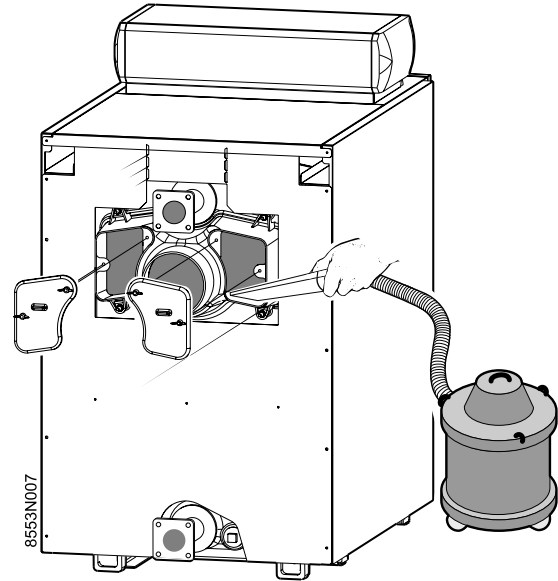

Baffle plates		Flue ways	P 320-4	P 320-5	P 320-6	P 320-7	P 320-8	P 320-9
upper	410 mm	A + B	-	8	8	4	-	-
	570 mm	A + B	4	-	-	4	8	8
interior	412 mm	C	2	2	2	2	2	2
	572 mm	C	-	-	-	-	-	2

## 5.2 Cleaning the casing material

Use a soapy solution and a sponge only. Rinse with clean water and dry with chamois leather or a soft cloth.

## 5.3 Precautions required in the case of long boiler stops

- The boiler and the chimney must be swept carefully.
- Close all the doors of the boiler to prevent air from circulating inside the boiler.
- We advise removing the pipe which connects the boiler to the chimney and to close off the nozzle with a cover.

## 5.4 Precautions required if the heating is stopped when there is a risk of freezing

We recommend the use of a correctly dosed antifreeze agent to prevent to the heating circuit from freezing. If this cannot be done, drain the system completely.



## 6 Burner maintenance

---

Refer to the instructions supplied with the burner.

## 7 System maintenance

---

### 7.1 Water level

---

Regularly check the level of water in the system and top up if required, taking care that cold water is not added suddenly into the boiler when it is hot.

This operation should be required only a few times in each heating season, with very low quantities of water; otherwise, look for the leak and repair it.

### 7.2 Draining

---

We advise you against draining the system unless it is absolutely necessary.

# 8 Type plate

The rating plate fixed on the side of the boiler during installation is used to identify the boiler correctly and also provides the main specifications of the boiler.

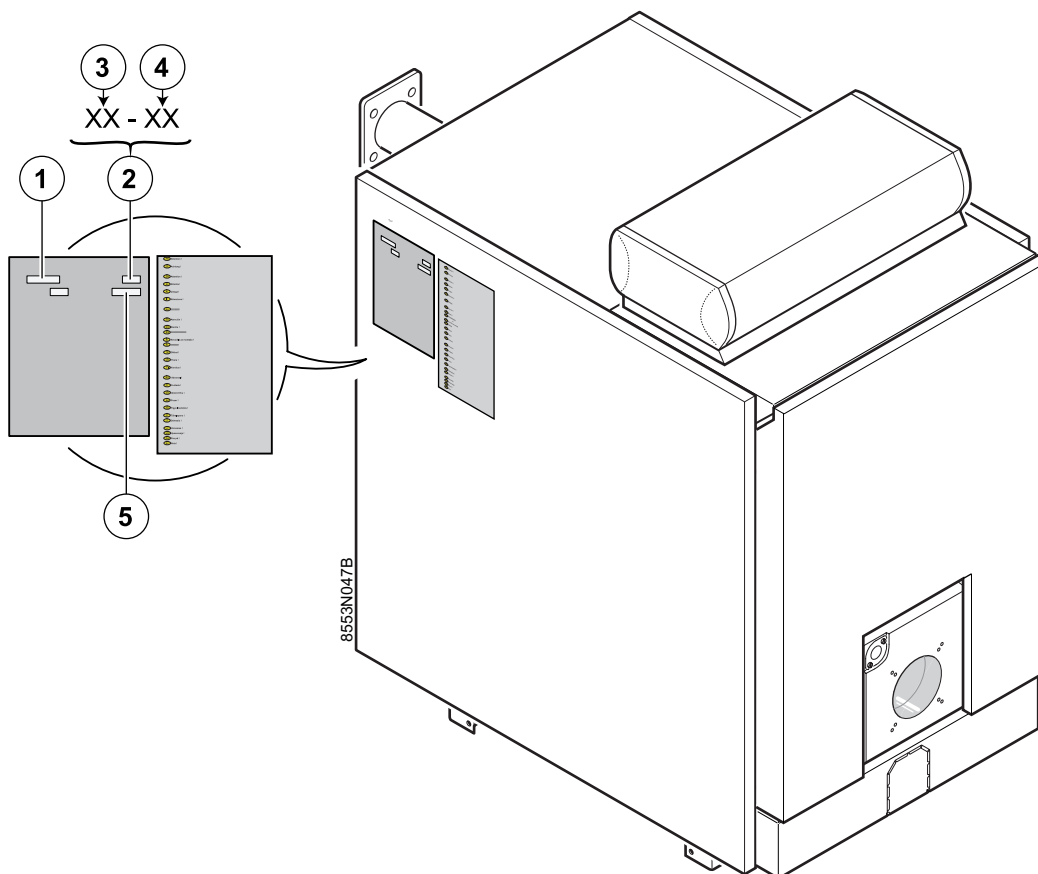

- ① Boiler type
- ② Manufacturing date
- ③ Year of manufacture
- ④ Week of manufacture
- ⑤ Serial no. of the appliance

# 9 Spare parts

**i** To order a spare part, quote the reference number next to the part required.

## Boiler body

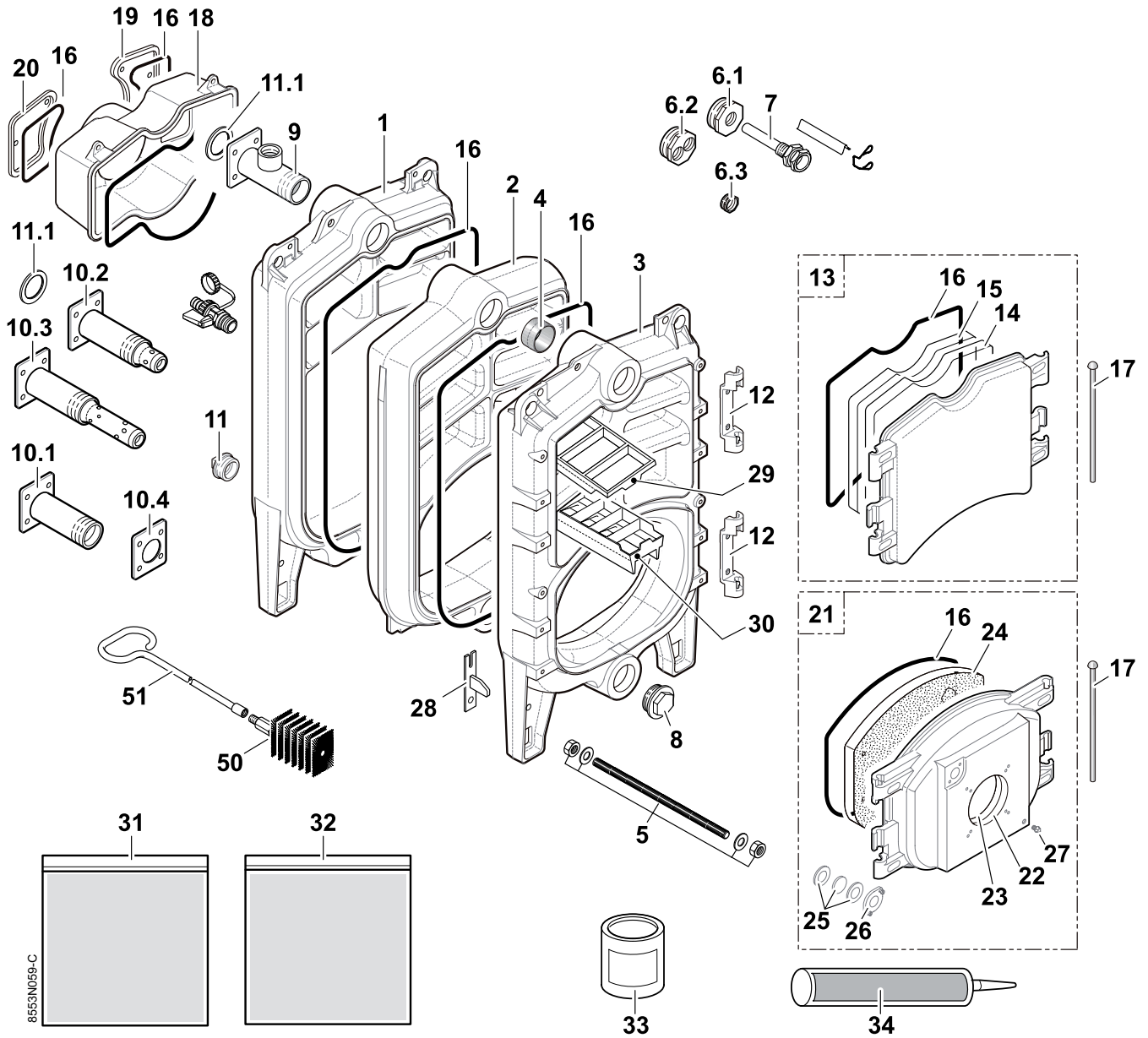

8553N059-C

## Insulation

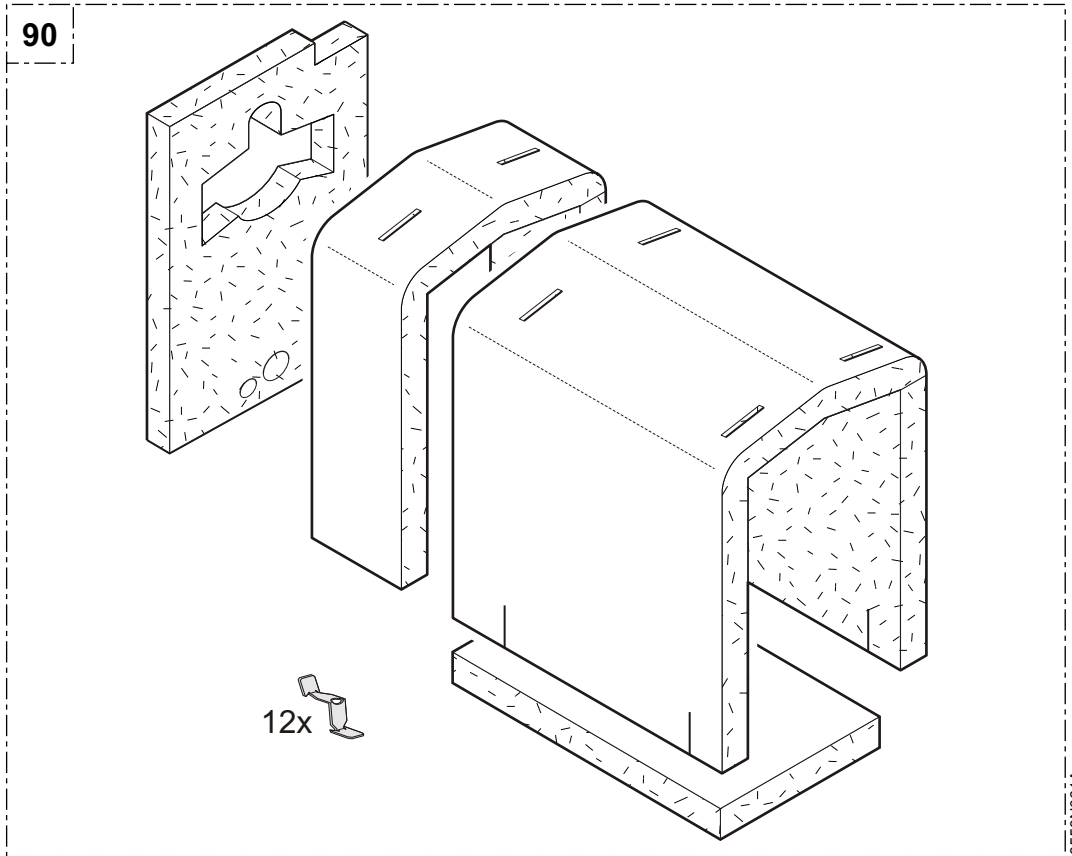

## Base frame

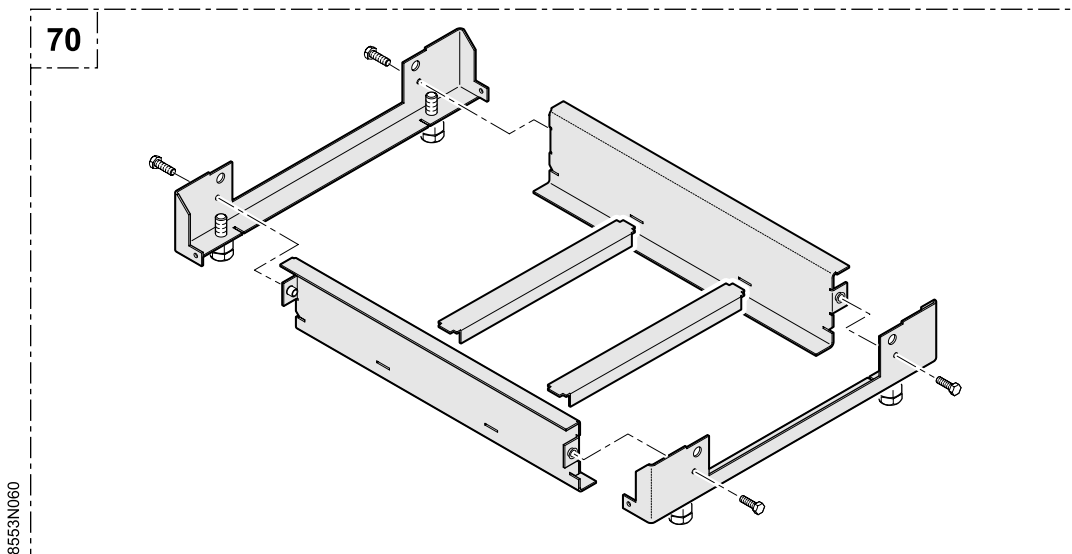

Casing - before week 14 / 2008

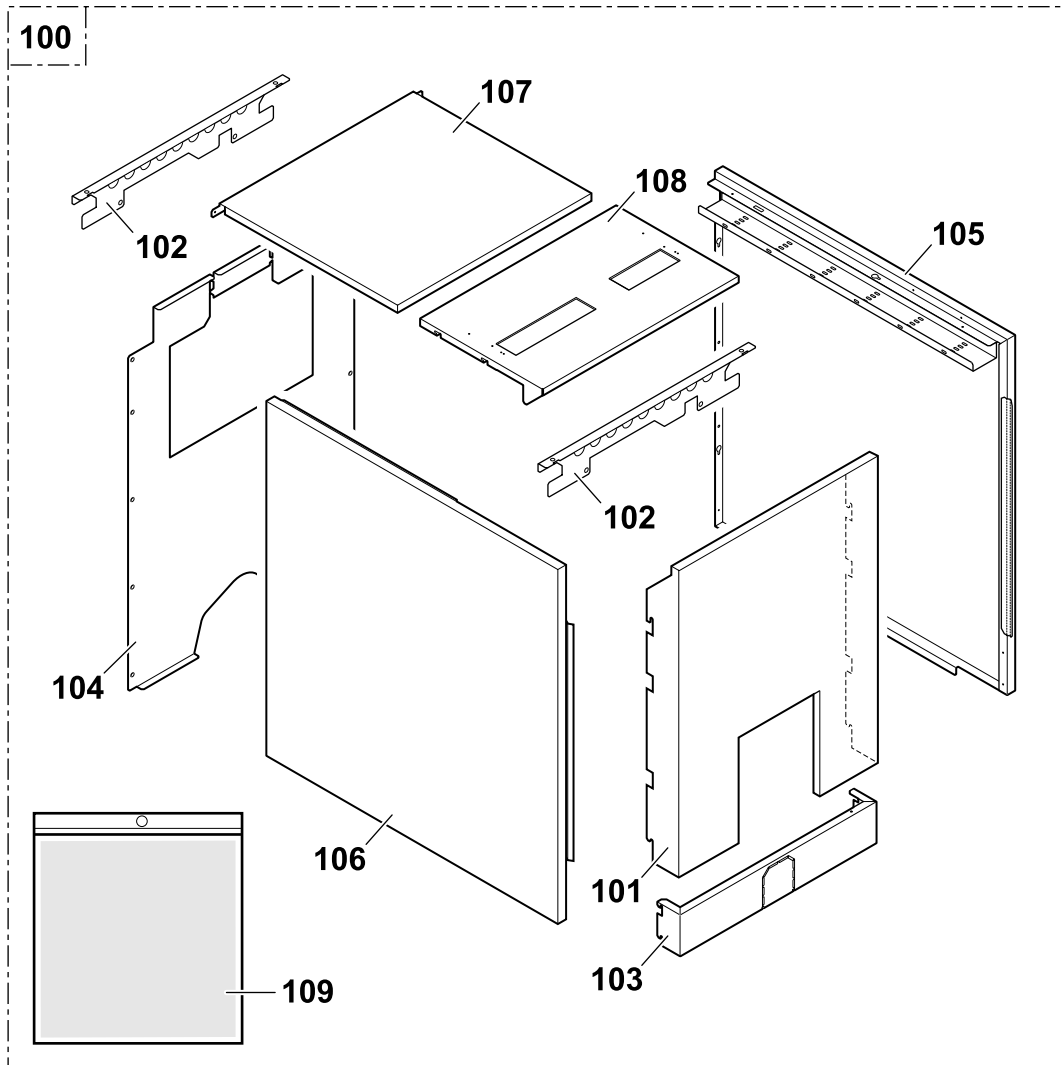

Casing - after week 14 / 2008

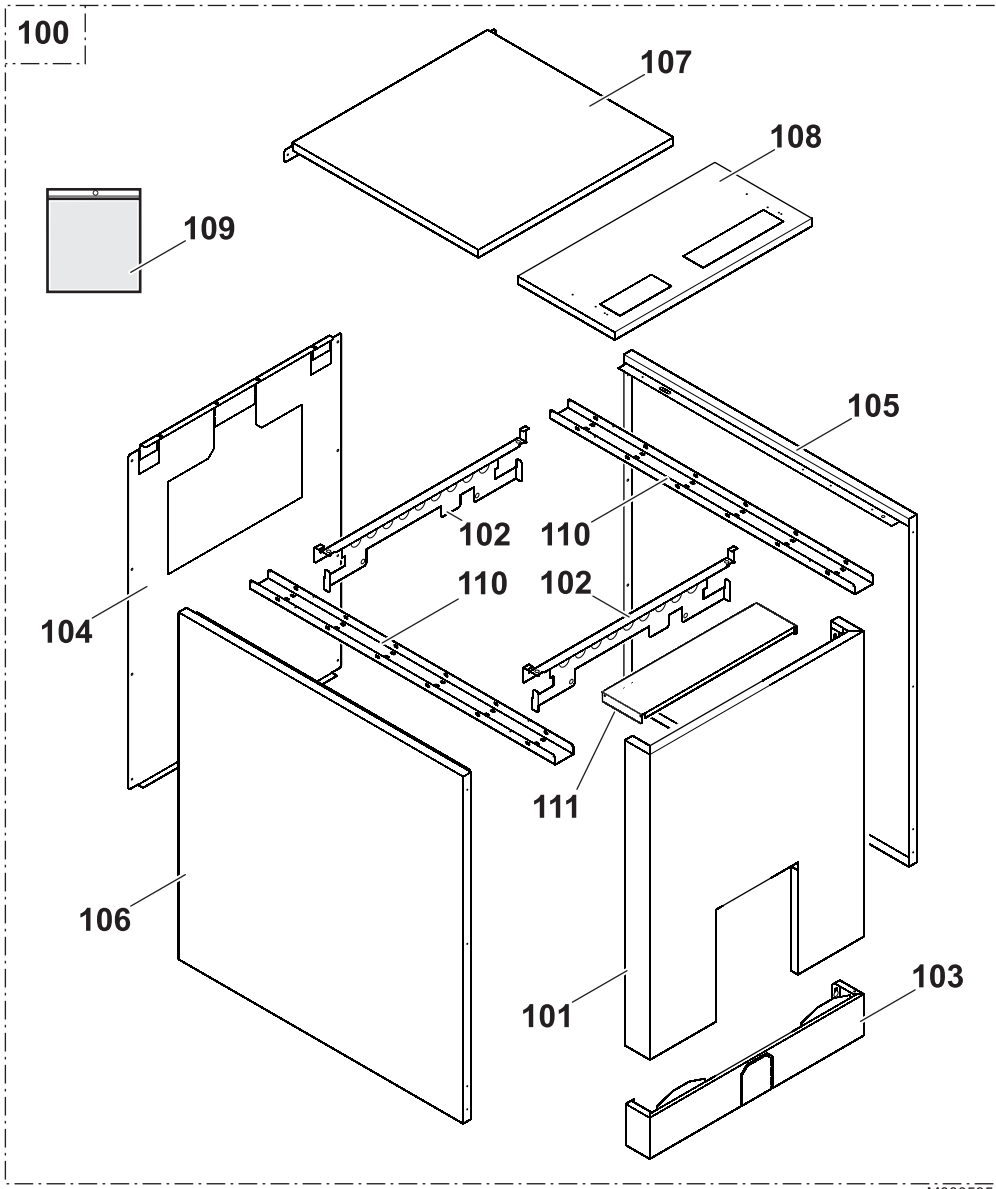

M000535A

Table - RC 6

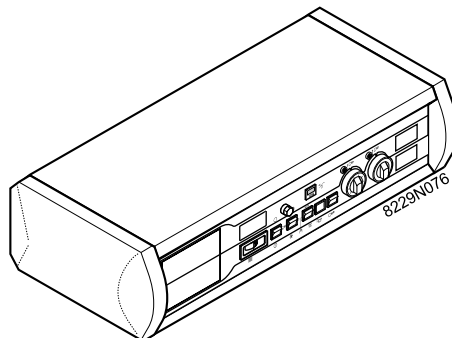

Markers	Code no.	Description
		<b>Boiler body</b>
1	8219-8912	Complete rear section
2	8219-8966	Special intermediate section
3	8219-8976	Complete front section
4	8116-0571	Nipple
5	8219-8968	Complete assembly rod, 4 sections
5	8219-8969	Complete assembly rod, 5 sections
5	8219-8970	Complete assembly rod, 6 sections
5	8219-8971	Complete assembly rod, 7 sections
5	8219-8972	Complete assembly rod, 8 sections
5	8219-8973	Complete assembly rod, 9 sections
6.1	8202-0028	Plug 2 1/2" - 1/2"
6.2	8209-0049	Plug 2 1/2" - 1/2" - NL
6.3	9494-8080	Nipple N 241 - 1/2"x1/4"
7	9536-5611	Rp 1/2 sensor tube
8	8013-0028	Solid plug 2" 1/2
9	8553-5513	Flow flange, 3 to 9 sections
10.1	8553-5514	Return flange, 4 to 5 sections
10.2	8553-5515	Return flange + distribution pipe, 6 to 8 sections
10.3	8553-5516	Return flange + distribution pipe, 9 sections
10.4	9754-9178	Counter flange
11	9495-0249	Male plug 290 T9 - R 1 1/2
11.1	9501-4122	Flange gasket
12	8104-8984	Hinge
13	8219-8916	Sweeping door
14	9425-0306	Inner protection, sweeping door
15	9425-0305	Insulation, sweeping door
16	9508-6032	10 Ø thermocord gasket
17	9756-0203	Pin Ø 12x350
18	8219-8913	Ø 180 complete nozzle
18	8219-8914	Ø 200 complete nozzle
19	8219-0206	Right hand nozzle cover
20	8219-0207	Left hand nozzle cover
21	8219-8953	Complete combustion chamber door, ø 135
22	9425-0303	Internal protection, combustion chamber door
23	9425-0302	Furnace door guard
24	9425-0301	Furnace door insulation
25	8015-7700	Sight glass + gaskets
26	9757-0027	Inspection flange
27	9495-0050	Plug 1/4"
28	8219-0539	Guide rail for combustion chamber door
29	8219-0017	Upper baffle plate, 410 mm
29	8219-0018	Upper baffle plate, 570 mm
30	8219-0019	Lower baffle plate, 412 mm
30	8219-0020	Lower baffle plate, 572 mm
31	8219-7724	Body screws packet
32	8219-8957	Bag of screws for furnace door
33	9430-5027	0.3 kg can nipple lubricant

Markers	Code no.	Description
34	9432-0214	Mastic Novasil S 17
		<b>Miscellaneous</b>
50	9750-5025	Brush
51	9750-5076	1000 mm brush rod
51	9750-5060	1300 mm brush rod
		<b>Base frame</b>
70	8553-7060	Complete frame 4 sections Package FD 30
70	8553-7061	Complete frame 5 sections Package FD 31
70	8553-7062	Complete frame 6 sections Package FD 32
70	8553-7063	Complete frame 7 sections Package FD 33
70	8553-7064	Complete frame 8 sections Package FD 34
70	8553-7065	Complete frame 9 sections Package FD 35
		<b>Insulation</b>
90	8553-5507	Complete boiler body insulation, 4 sections
90	8553-5508	Complete boiler body insulation, 5 sections
90	8553-5509	Complete boiler body insulation, 6 sections
90	8553-5510	Complete boiler body insulation, 7 sections
90	8553-5511	Complete boiler body insulation, 8 sections
90	8953-5512	Complete boiler body insulation, 9 sections
		<b>Casing - after week 14 / 2008</b>
100	100004865	Complete casing 4 sections
100	100004866	Complete casing 5
100	100004867	Complete casing 6
100	100004868	Complete casing 7
100	100004869	Complete casing 8
100	100004880	Complete casing 9
101	200013020	Front panel
102	200004840	Upper crosspiece
103	200004839	Lower cap
104	200005032	Complete rear panel
105	200005033	Complete side panel right, 4 sections
105	200005034	Complete side panel right, 5 sections
105	200005035	Complete side panel right, 6 sections
105	200005036	Complete side panel right, 7 sections
105	200005037	Complete side panel right, 8 sections
105	200005038	Complete side panel right, 9 sections
106	200005039	Complete side panel left, 4 sections
106	200005040	Complete side panel left, 5 sections
106	200005041	Complete side panel left, 6 sections
106	200005042	Complete side panel left, 7 sections

Markers	Code no.	Description
106	200005043	Complete side panel left, 8 sections
106	200005044	Complete side panel left, 9 sections
107	200004830	Complete rear cover, 4 sections
107	200004831	Complete rear cover, 5 sections
107	200004832	Complete rear cover, 6 sections
107	200004833	Complete rear cover, 7 sections
107	200004834	Complete rear cover, 8 sections
107	200004835	Complete rear cover, 9 sections
108	200005045	Complete front cover
109	200005046	Screw bag
110	200004849	4-section cable way
110	200004850	5-section cable way
110	200004851	6-section cable way
110	200004852	7-section cable way
110	200004853	8-section cable way
110	200004854	9-section cable way
111	200004841	Cable protection
	<b>Casing - before week 14 / 2008</b>	
100	100003501	Complete casing 4 sections
100	100003502	Complete casing 5
100	100003503	Complete casing 6
100	100003504	Complete casing 7
100	100003505	Complete casing 8
100	100003506	Complete casing 9
101	200003545	Front panel
102	8553-8000	Upper crosspiece
103	8553-5506	Lower cap
104	8553-8519	Complete rear panel
105	8553-8545	Complete side panel right, 4 sections
105	8553-8546	Complete side panel right, 5 sections
105	8553-8547	Complete side panel right, 6 sections
105	8553-8548	Complete side panel right, 7 sections
105	8553-8549	Complete side panel right, 8 sections
105	8553-8550	Complete side panel right, 9 sections
106	8553-8551	Complete side panel left, 4 sections
106	8553-8552	Complete side panel left, 5 sections
106	8553-8553	Complete side panel left, 6 sections
106	8553-8554	Complete side panel left, 7 sections
106	8553-8555	Complete side panel left, 8 sections
106	8553-8556	Complete side panel left, 9 sections
107	8553-8512	Complete rear cover, 4 sections
107	8553-8513	Complete rear cover, 5 sections
107	8553-8514	Complete rear cover, 6 sections
107	8553-8515	Complete rear cover, 7 sections
107	8553-8516	Complete rear cover, 8 sections
107	8553-8517	Complete rear cover, 9 sections
108	8553-8518	Complete front cover

Markers	Code no.	Description
109	8553-8520	Screw bag - Casing
		<b>K - RC 6 control panel</b>
		Refer to the Spare Parts list in the panel instructions.









- NL Remeha B.V.**  
Postbus 32  
7300 AA APELDOORN  
Tel: +31 55 5496969  
Fax: +31 55 5496496  
Internet: nl.remeha.com  
E-mail: remeha@remeha.com
- B J.L. Mampaey BVBA**  
Uitbreidingstraat 54  
2600 ANTWERPEN  
Tel: +32 3 2307106  
Fax: +32 3 2301153  
Internet: www.mampaey.be  
E-mail: info@mampaey.be
- B Thema S.A.**  
6, Avenue de l'expansion  
4460 GRACE-HOLLOGNE  
Tel: +32 4 2469575  
Fax: +32 4 2469576  
Internet: www.thema-sa.be  
E-mail: info@thema-sa.be
- E Termibarna S.A.**  
C. Zamora 55-59  
08005 BARCELONA  
Tel: +34 3 3000204  
Fax: +34 3 3009558
- E D.A.C. S.A.**  
Tomás A. Edison 29  
Poligono Cogullada  
50014 ZARAGOZA  
Tel: +34 76 464076  
Fax: +34 76 471311  
Internet: www.dac.es  
E-mail: dac@dac.es
- E Cuatrocesa S.A.**  
c) Sor Angela de La Cruz, 10  
- 1º Oficina C  
28020 MADRID  
Tel: +34 91 658 18 88  
Fax: +34 91 658 30 77
- E Norte Comercial Organización S.A.**  
Bereteage Bidea, 19  
48180 LOIU (Vizcaya)  
Tel: +34 94 471 03 33  
Fax: +34 94 471 11 52  
E-mail: nco@nco.es
- GB Remeha Commercial UK**  
Part of the BDR THERMEA  
Remeha House  
Molly Millars Lane  
RQ41 2QP Wokingham, Berks  
After Sales Tel: 01189743076  
Technical Enquires: 01189743067  
Internet: www.remeha.co.uk
- H Marketbau - Remeha Kft.**  
Gyár u. 2.  
Ipari Park  
2040 BUDAÖRS  
Tel: +36 23 503 980  
Fax: +36 23 503 981  
Internet: www.remeha.hu  
E-mail: remeha@remeha.hu
- IRL Euro Gas Ltd.**  
Unit 38, Southern Cross Business Park  
Boghall Road, Bray, Co  
WICKLOW  
Tel: +353 12868244  
Fax: +353 12861729  
Internet: www.eurogas.ie  
E-mail: sales@eurogas.ie
- IT Revis S.r.l**  
Via Trieste 4a  
31025 Santa Lucia di Piave (TV)  
Tel: +39 0438 701907  
Fax: +39 02 36028583  
Internet: www.re-vis.it  
E-mail: info@re-vis.it

© Copyright

All technical and technological information contained in these technical instructions, as well as any drawings and technical descriptions supplied, remain our property and shall not be multiplied without our prior consent in writing.

Subject to alterations.

02/11/2015

